

B-25J Mitchell User Manual

Wingspan: 1600mm

Length: 1280mm

Empty Weight: 3050G[w/o Battery]

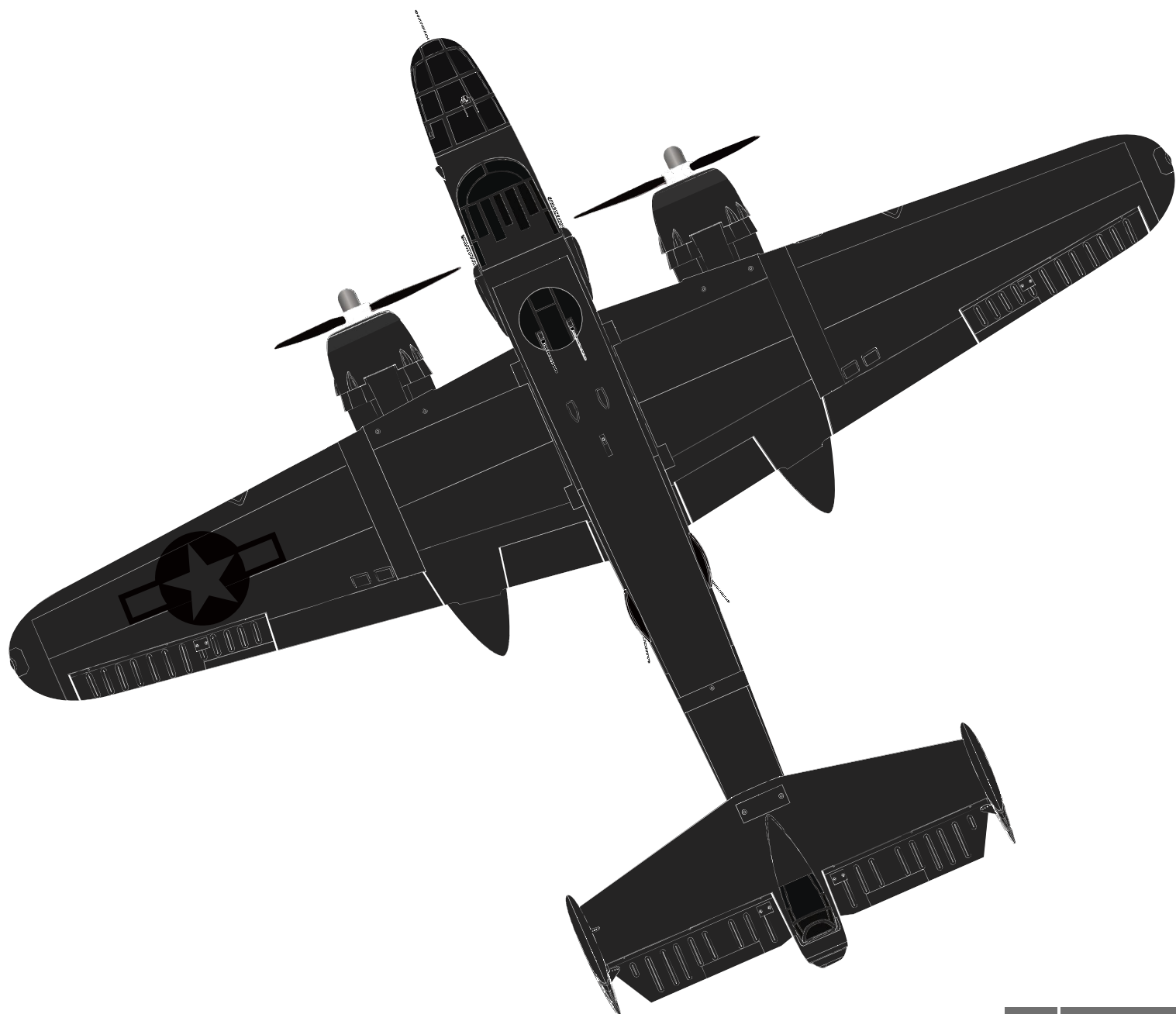

EN

1~12

- 1 Introduction
- 2 Product basic information
- 2 Package list
- PNP Assembly instructions
- 3 Install vertical stabilizer
- 3 Install horizontal stabilizer
- 4 Install fuselage tail
- 4 Install inside wing
- 5 Install outside wing
- 5 Install the propeller
- 6 Install other accessories
- 6 Install bombs
- 7 Pushrod instructions
- 7 Important additional notes
- 8 Install battery
- 9 Center of gravity
- PNP Parameter setting
- 10 Dual rates
- 10 Remote control EXP setting suggestion
- 11 Flight note
- 11 Control direction test
- Pre-installed component overview
- 12 Servo direction
- 12 Motor specification

Thank you for purchasing the FlightLine RC B-25 Mitchell RC model airplane. FlightLine RC is a leading brand produced by Freewing Model. When you assemble and use this model airplane, please carefully read the instructions and follow the instructions to assemble and debug the product. During this process, if any problems are found, please contact the seller immediately or log in to the official website: www.freewingmodel.com^①. Contact us directly through the contact information provided in the "Contact Us" section, and we will provide you with all necessary assistance!

The FlightLineRC B-25J Mitchell twin propeller bomber model is approximately 1/13 scale, with a 1600mm wingspan and 1280mm length. Constructed from EPO foam, PNP weight is 3420g, preinstalled two set 6S brushless power system, a complete set of CNC aluminum alloy scale shock absorbing landing gear, complete cabin doors and cabin door control units. Four LED aviation lights are distributed on the left and right main wings respectively. In the middle of the belly, there is a bomb bay containing four bomb models, which can be dropped through the control hatch.

The FlightLineRC B-25J Mitchell twin propeller bomber model adopts a new generation of Freewing structural design, improved the convenience of its portability and reuse. It uses the three section main wing design, two outer main wings, using a "QUICK" portable install structure, without screws to install. The front and rear fuselage are fixed with clips and screws. Other components (including plastic decorative parts) are fixed using screws or tight fitting methods. The main wing and load-bearing parts of the fuselage are equipped with a large number of carbon fiber tubes, further enhancing the strength of the fuselage. The PNP version is pre painted, labeled the plane emblem at factory, and provide three different sets of decals^② for selection.

The new generation 6S powered FlightLine B-25J model airplane has abundant power, short takeoff and roll distance (about 20 meters), and a maximum level flight speed of about 143KPH (89.4MPH)^③. Test at full throttle on the ground, with a continuous current of approximately 33A on one side. The 6S 5000mAh capacity battery can maintain an idle flight time of about 10 minutes^④. The FlightLine B-25J model aircraft flies smoothly in the air, and during the control process, its actions respond quickly and its posture changes accurately. The larger size of the front and rear wheels^⑤ can provide the aircraft with the ability to take off and land on the grass.

This FlightLine's first model aircraft launched in 2023 features a new structural and spatial design concept, as well as more refined exterior details. We hope you enjoy it!

Illustrate:

- ① Please recognize: www.freewingmodel.com and www.sz-freewing.com (old) They are the correct website addresses for our company, and do not trust other fake link addresses to prevent being deceived.
- ② The three decals names are: Heavenly body, Executive sweet, Mitch the switch. Among them, some painting schemes require additional local painting and coloring to achieve a 100% true painting effect.
- ③ This result is the average of the highest speeds obtained from multiple flight tests of the aircraft in full throttle level flight (without dive acceleration action). Different weather environments and equipment may lead to differences. This result is for reference only.
- ④ The battery for endurance testing is: Admiral 6S 22.2V 5000mAh 50C, with different brands of the same model, or with different levels of new or old batteries of the same brand, the actual endurance time may vary. The test results here are for reference only.
- ⑤ The specifications of the front and rear wheels of this product are: $\varnothing 60 \times 16\text{mm}$, $\varnothing 85 \times 26\text{mm}$. Please use this size parameter to determine whether it is suitable for takeoff and landing in the current grass environment.

⚠Warning: This is not a toy. Not for children under 14 years. Young people under the age of 14 should only be permitted to operate this model under the instruction and supervision of an adult. Please keep these instructions for further reference after completing model assembly.

Note:

1. This is not a toy! Operator should have a certain experience, beginners should operate under the guidance of professional players.
2. Before install, please read through the instructions carefully and operate strictly under instructions.
3. Cause of wrong operation, Freewing and its vendors will not be held responsible for any losses.
4. Model planes' players must be on the age of 14 years old.
5. This plane used the EPO material with surface spray paint, don't use chemical to clean, otherwise it will damage.
6. You should be careful to avoid flying in areas such as public places, high-voltage-intensive areas, near the highway, near the airport or any other place where laws and regulation clearly prohibit.
7. You cannot fly in bad weather conditions such as thunderstorms, snows....
8. Model plane's battery, don't allowed to put in everywhere. Storage must ensure that there is no inflammable and explosive materials in the round of 2M range.
9. Damaged or scrap battery should be properly recycled, it can't discard to avoid spontaneous combustion and fire.
10. In flying field, the waste after flying should be properly handled, it can't be abandoned or burned.
11. In any case, you must ensure that the throttle is in the low position and transmitter switch on, then it can connect the lipo-battery in aircraft.
12. Do not try to take planes by hand when flying or slow landing process. You must wait for landing stop, then carry it.

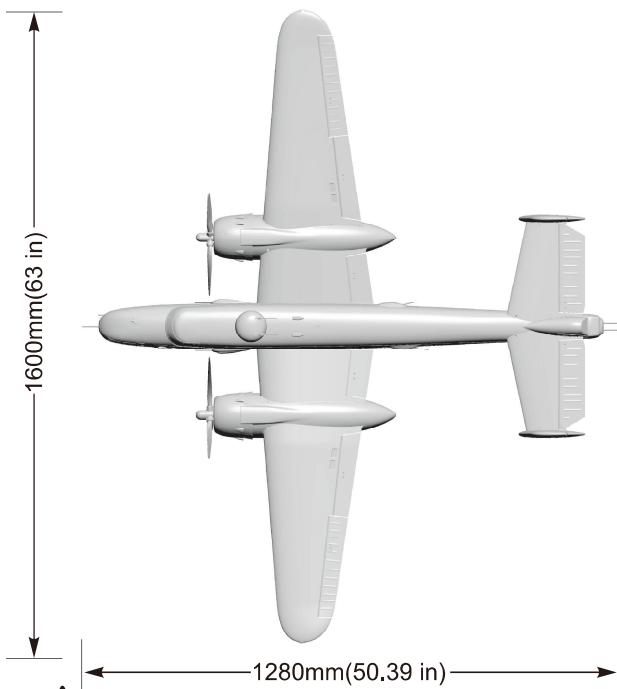

Standard Version

Wingload: 135g/dm²
 Wing Area: 31 dm²
 Motor: 3748-450KV O/R Motor ×2
 Servo: 9g Plastic digital servo ×4
 9g Hybrid digital servo ×7
 17g MG digital servo ×4
 ESC: 50A Brushless ×2 7A UBEC
 Propeller: 12x7 Blade
 (Standard ×1, Reverse ×1)
 Weight: 3050g (w/o Battery)

Other features

Material: EPO & Plastic
 Aileron: Yes Flaps: Yes
 Elevator: Yes Rudder: Yes
 Landing gear: Electric Landing Gear
 Cabin door: Yes
 Scale LED lights
 Scale Pilot figure ×2
 Li-Po Battery: 6S 5000-5500mAh

⚠ Note: The parameters in here are derived from test result using our accessories. If use other accessories, the test result will be different. Any problem since of using other accessories, we are not able to provide technical support.

Package List

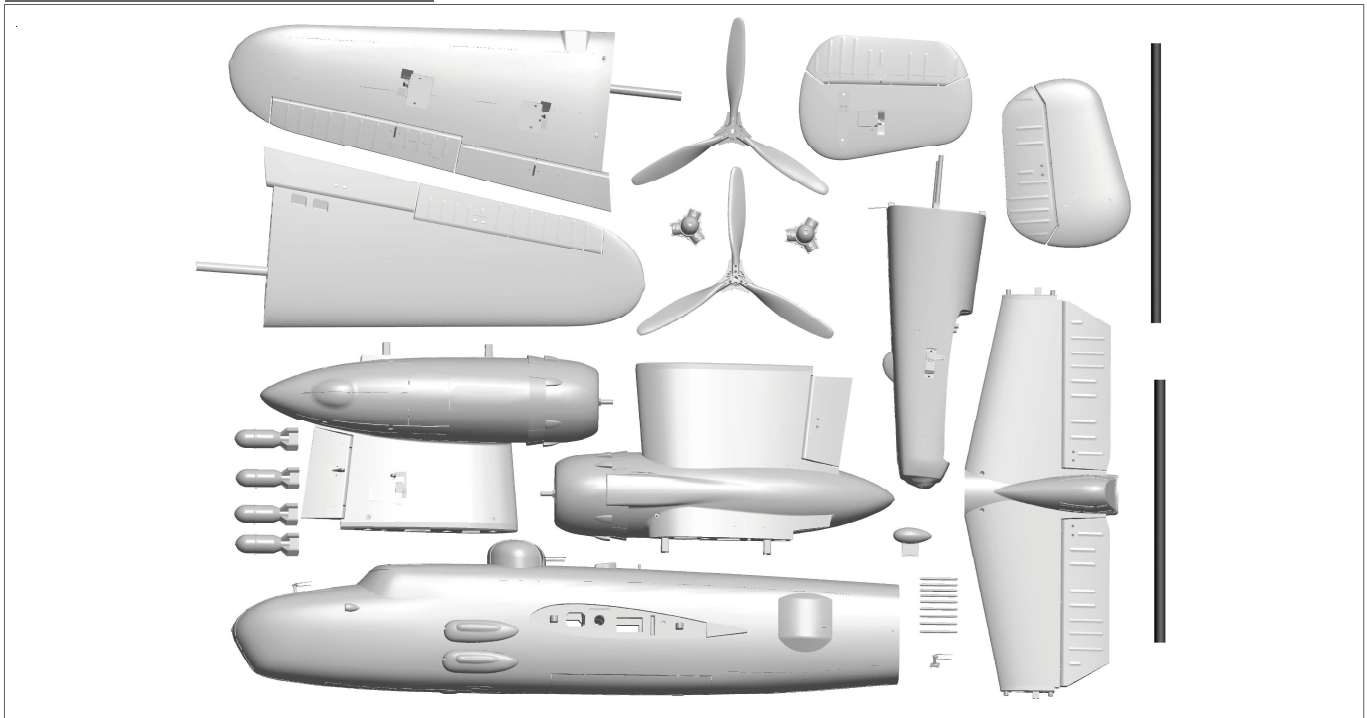

Different equipment include different spareparts. Please refer to the following contents to check your sparepart list.

No.	Name	PNP	ARF Plus	No.	Name	PNP	ARF Plus
1	Fuselage (front)	Pre-installed all electronic parts	Pre-installed servo	9	Carbon tube 2 pcs	✓	✓
2	Fuselage (rear)	Pre-installed all electronic parts	Pre-installed servo	10	other scale plastic parts	✓	✓
3	Main wing (left/right outside)	Pre-installed all electronic parts	Pre-installed servo	11	Manual	✓	✓
4	Main wing (left/right inside)	Pre-installed all electronic parts	Pre-installed servo	12	Pushrod	✓	✓
5	Vertical tail (left/right)	Pre-installed all electronic parts	Pre-installed servo	13	Screw bag	✓	✓
6	Horizontal tail	✓	✓	14	Non-slip mat	✓	✓
7	Bombs	✓	✓	15	Glue	✓	✓
8	Propeller(standard/reverse)	✓	✓				

Install the vertical stabilizer

As the photo show:

1. Pull the left /right rudder servo cables along the slots into the horizontal tail;
2. Fix the left/right vertical tails respectively on the horizontal tail and fix them with 4 screws.

Screw (KA3X10mm 4pcs)

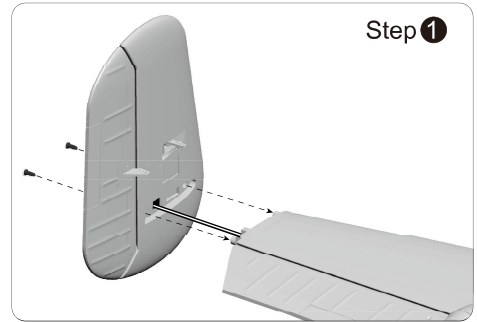

Step 1

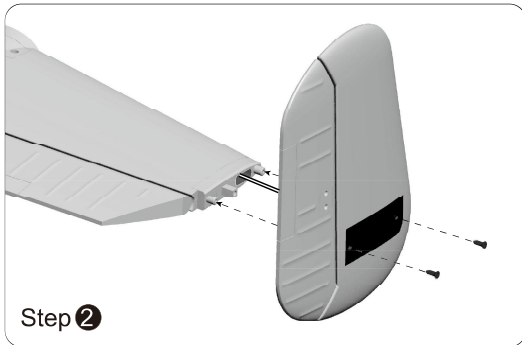

Step 2

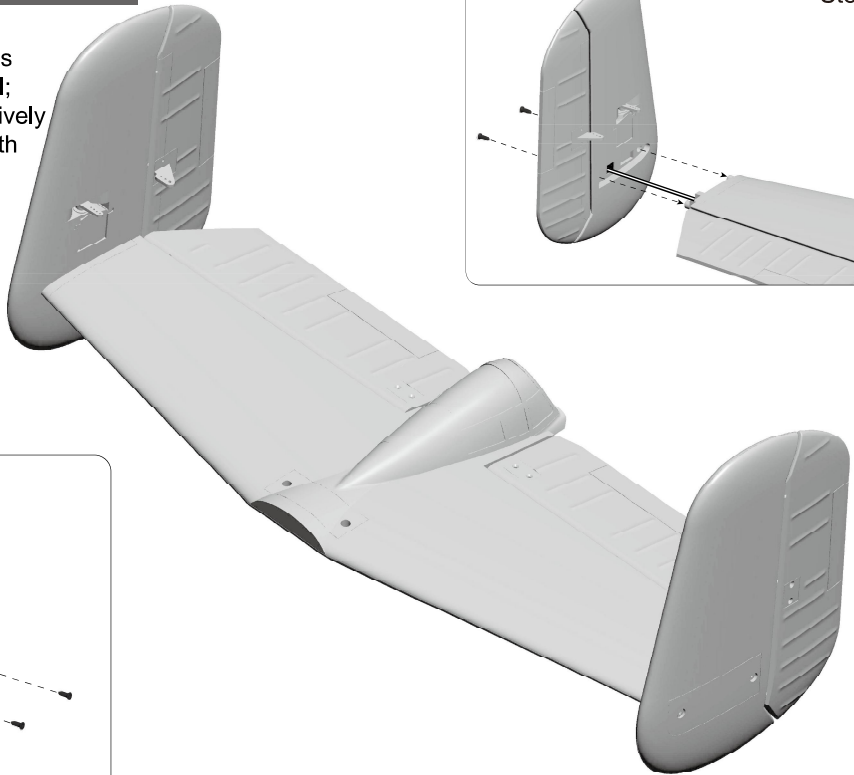

Install the horizontal stabilizer

As the photo show:

1. Insert the servo cables of vertical/horizontal tail onto the PCB board at the rear fuselage, the elevator servo cable is inserted into the ELE interface, and the rudder servo cable is inserted into the RUD interface;
2. Fix the installed horizontal tail to the rear fuselage with screws.

Screw (KA3X10mm 3pcs)

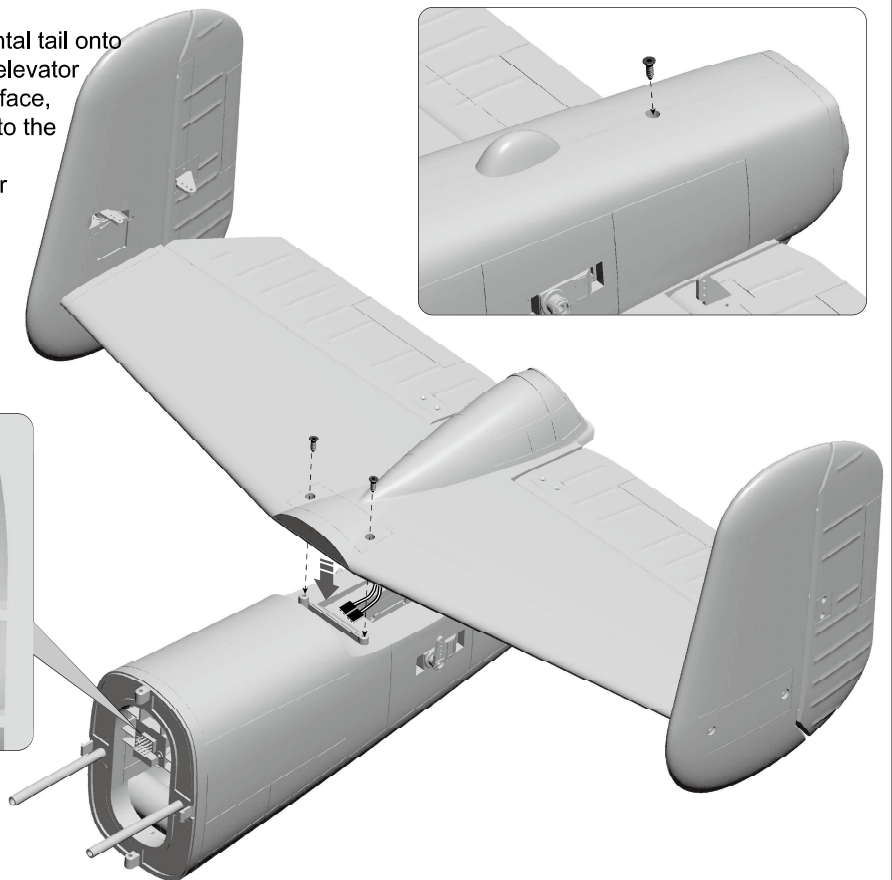
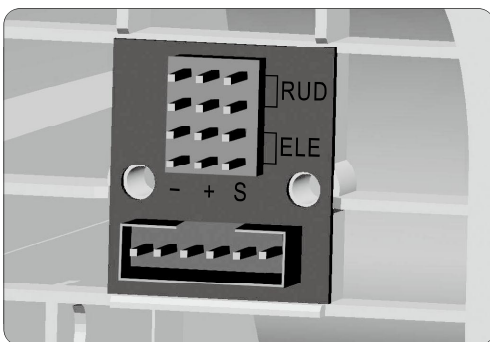
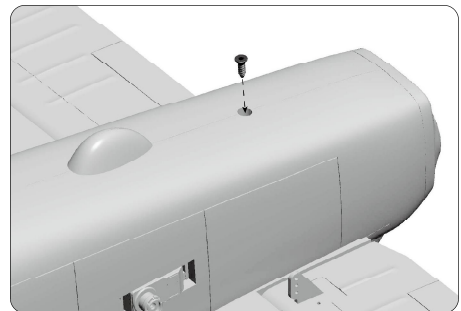

Install the fuselage tail

As the photo show:

1. Install conical plastic parts onto carbon tube;
2. Insert the ribbon wire of the front fuselage into the PCB board;
3. Install the rear fuselage on the fuselage and fix it with screws.

Screw (KA3X10mm 2pcs)

Step 1

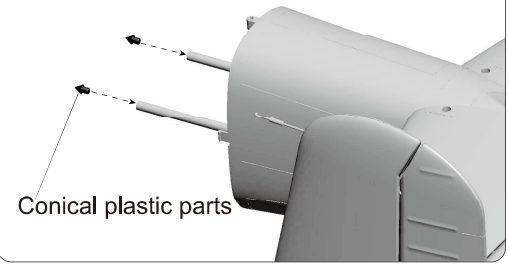

Conical plastic parts

Step 3

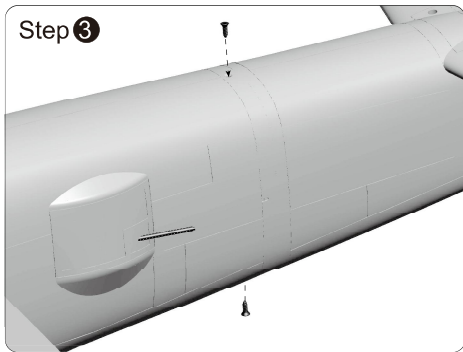

Install inside wing

As the photo show:

1. Insert the carbon tube A,B into the fuselage;
2. Insert the ribbon wire into the main wing control board, then insert the servo cables;
3. Thread the ESC and ESC signal cables into the fuselage and install the left/right wing on the fuselage;
4. Use 4pcs screws to fix the main wing.

Screw (M4X16mm 4pcs)

Step 1

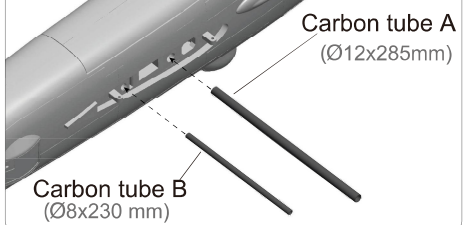

Carbon tube A (Ø12x285mm)

Carbon tube B (Ø8x230 mm)

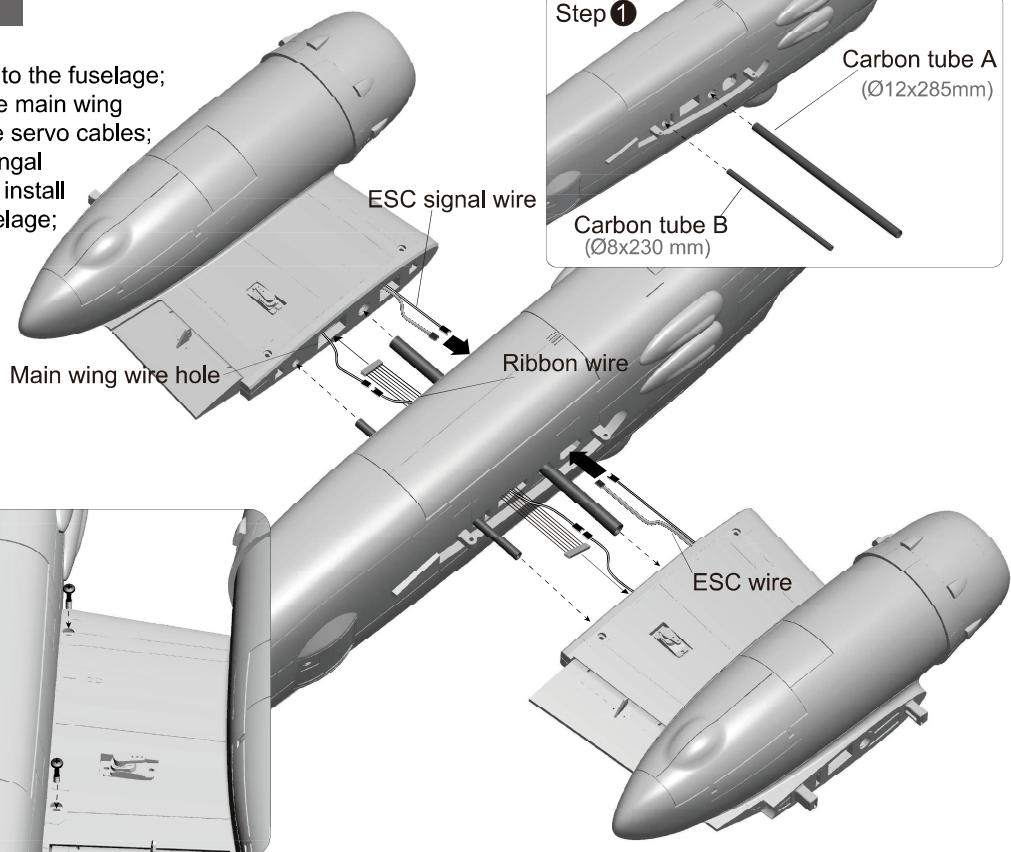

Step 3

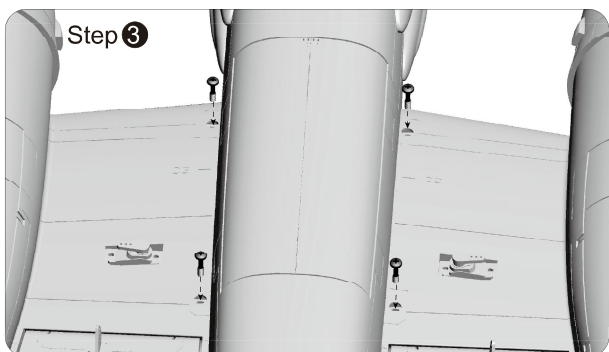

Install out side main wing

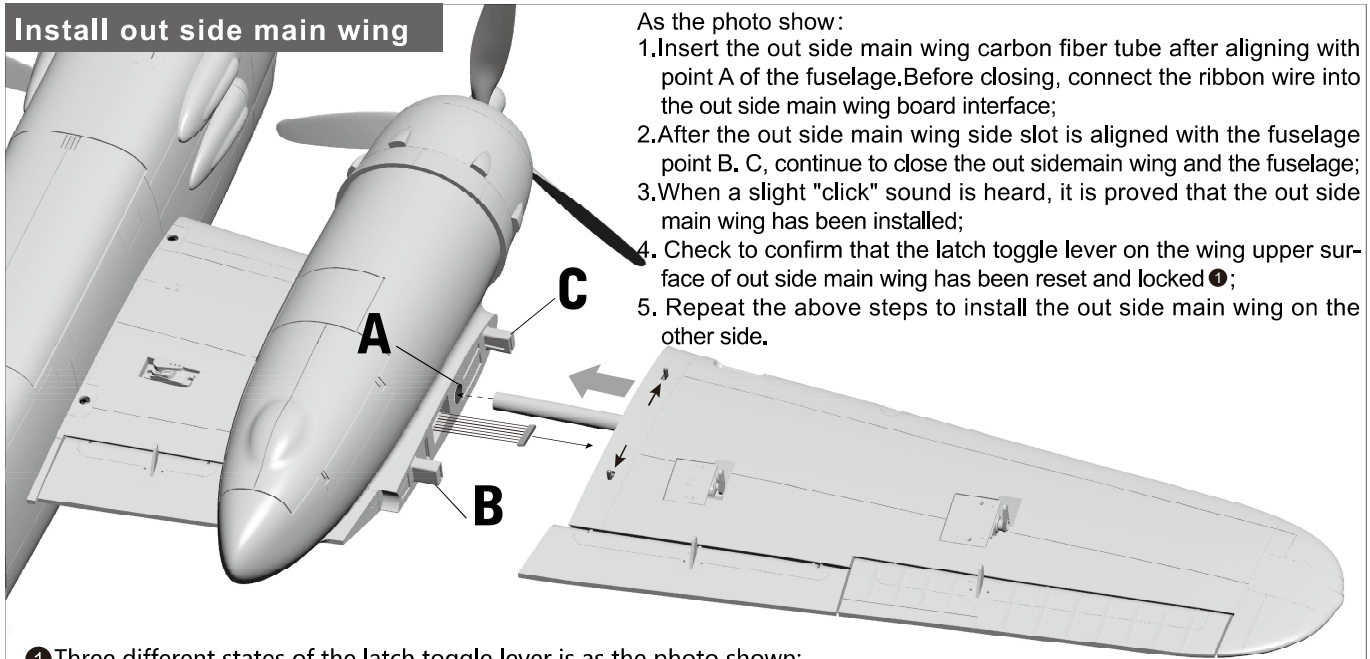

As the photo show:

1. Insert the out side main wing carbon fiber tube after aligning with point A of the fuselage. Before closing, connect the ribbon wire into the out side main wing board interface;
2. After the out side main wing side slot is aligned with the fuselage point B, C, continue to close the out side main wing and the fuselage;
3. When a slight "click" sound is heard, it is proved that the out side main wing has been installed;
4. Check to confirm that the latch toggle lever on the wing upper surface of out side main wing has been reset and locked ①;
5. Repeat the above steps to install the out side main wing on the other side.

① Three different states of the latch toggle lever is as the photo shown:

Latch toggle lever lock status

As the photo show, the front/rear lever is in outside end point

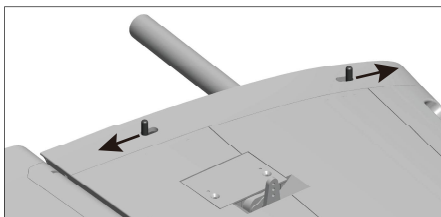

When unlocking, it is necessary to manually push the front and rear toggle levers towards the middle at the same time.

Latch toggle lever unlock status

As the photo show, the front/rear lever is in inside end point

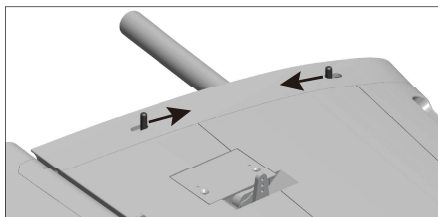

The latch toggle lever abnormal status

As the photo show, the front/rear lever is not in outside or inside end points

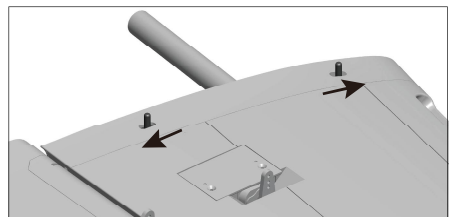

After installed the main wing, please check carefully. If happen the abnormal status, it is necessary to manually push the latch toggle lever to reset.

Install the propeller

As the photo show:

1. Fix the propeller on the motor.
2. As the photo show, install the left/right propeller.

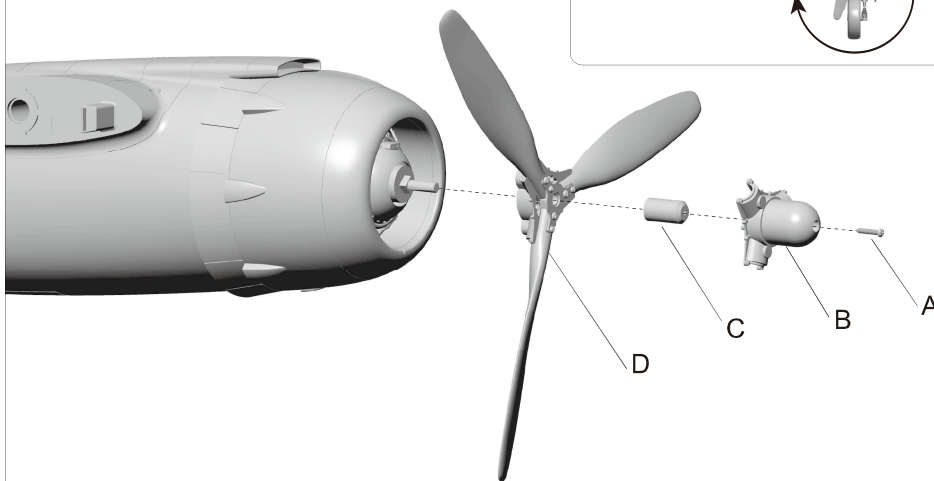
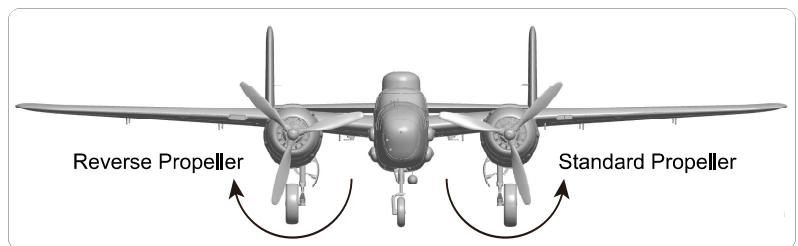

- A - Screw (KM3x10mm 2pcs)
- B - Spinner
- C - Screw nut
- D - Scale propeller

Install scale decorated parts

1.As shown in the photo below, install various scale accessories such as antennas, machine guns, and hangers on the fuselage.

Note: When installing, first try to install the correct accessories into the mounting holes to know the depth of the accessories installation. Then apply a small amount of glue to the part that needs to be inserted into the foam for installation. This method of operation is much better than dripping the glue directly into the fine foam cells, which can reduce the overflow of the glue as much as possible and prevent the glue from staining the foam surface.

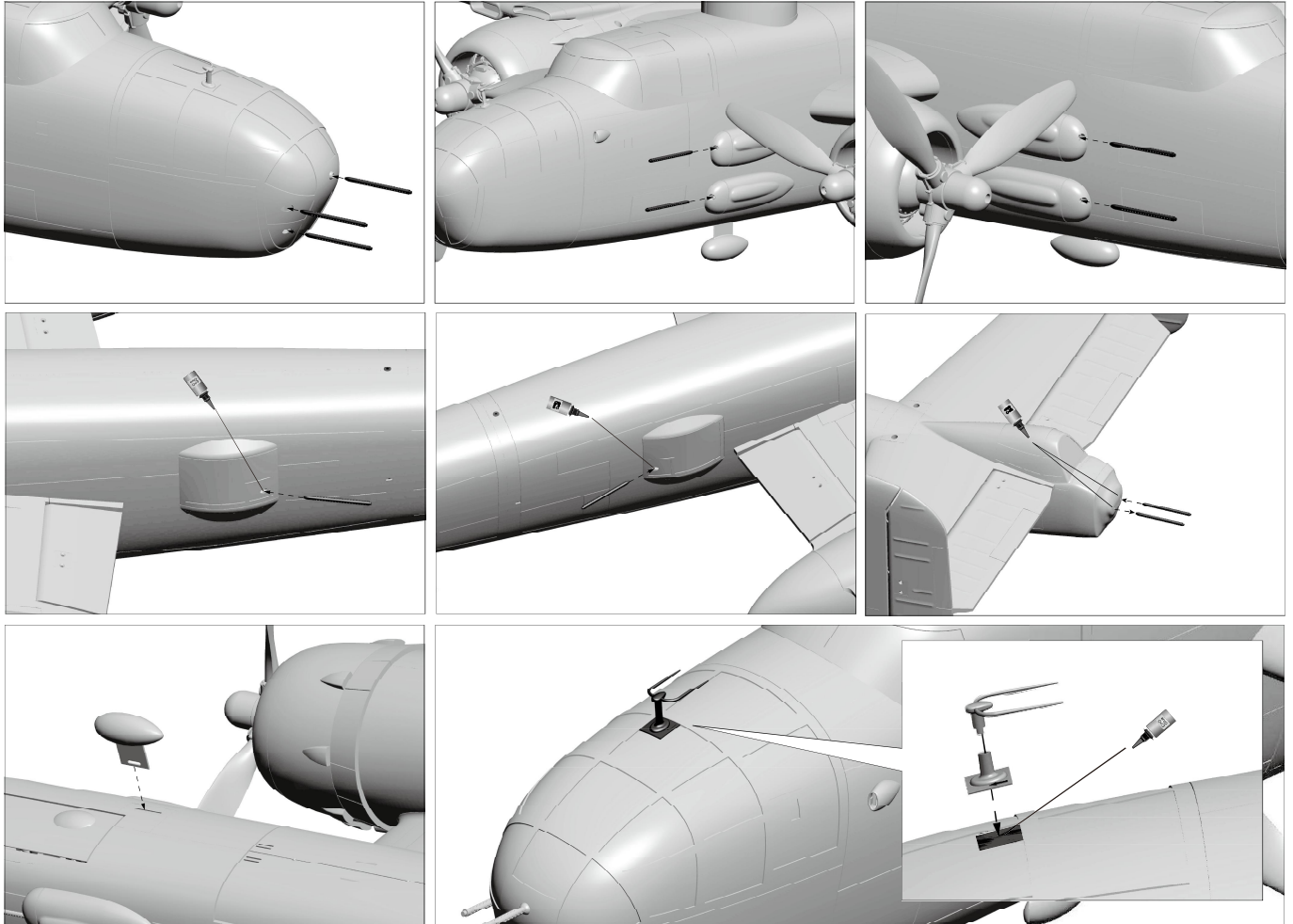

Install Bombs

As the photo show:
1.Turn over the fuselage, open the bombs compartment, and put the bombs in it.

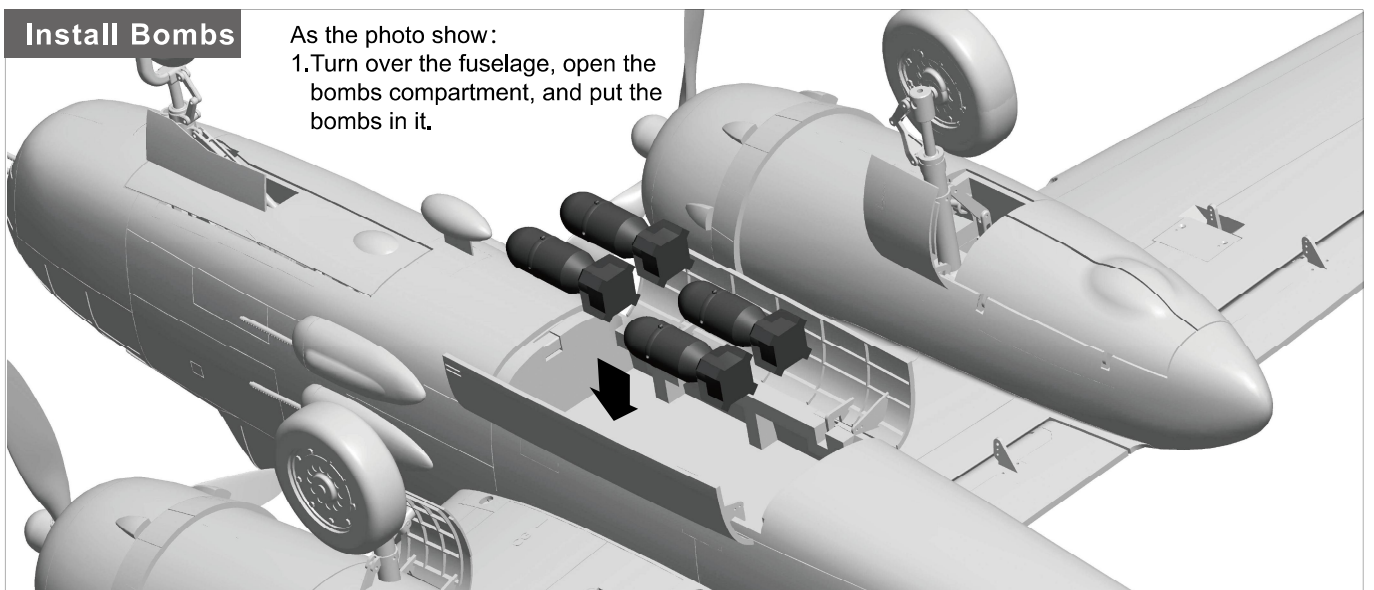

Pushrod instructions

Nose gear steering pushrod length

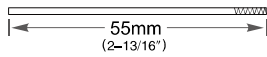

Pushrod diameter : Ø1,2mm

Nose gear steering pushrod mounting hole



Nose cabin door pushrod length

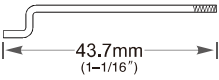

Pushrod diameter : Ø1,2mm

Nose cabin door pushrod mounting hole



Rear cabin door pushrod length



Pushrod diameter : Ø1,2mm

Rear cabin door pushrod mounting hole

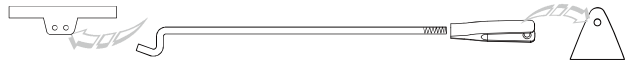

Rear cabin door pushrod length

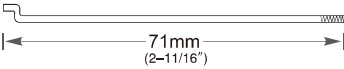

Pushrod diameter : Ø1,2mm

Rear cabin door pushrod mounting hole



Bombs compartment door pushrod length

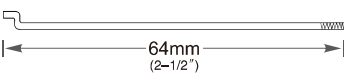

Pushrod diameter : Ø1,2mm

Bombs compartment door pushrod mounting hole



Rudder pushrod length

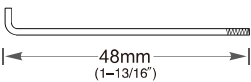

Pushrod diameter : Ø1,2mm

Rudder pushrod mounting hole



Elevator pushrod length



Pushrod diameter : Ø1,2mm

Elevator pushrod mounting hole



Aileron pushrod length

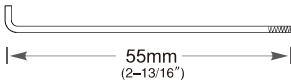

Pushrod diameter : Ø1,2mm

Aileron pushrod mounting hole



Flap pushrod length(inside)

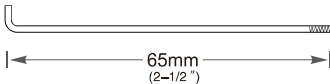

Pushrod diameter : Ø1,2mm

Flap pushrod mounting hole(inside)



Flap pushrod length(outside)

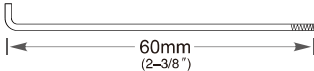

Pushrod diameter : Ø1,2mm

Flap pushrod mounting hole(outside)



Important additional notes

The Y-type clevis used in this product is equipped with a transparent silicone ring for secondary reinforcement, which can effectively prevent the clevis from accidentally loosening.

As shown in the following figure, when you buckle the clevis into the control surface horn, use the silicone ring to cover the clevis.

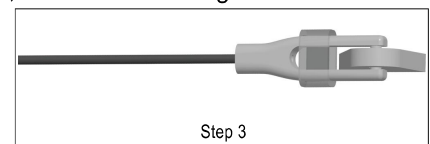
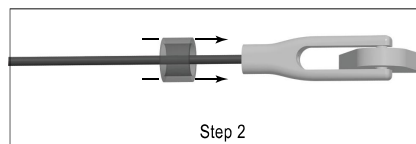
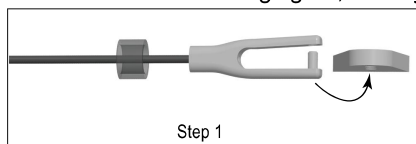

Install Battery

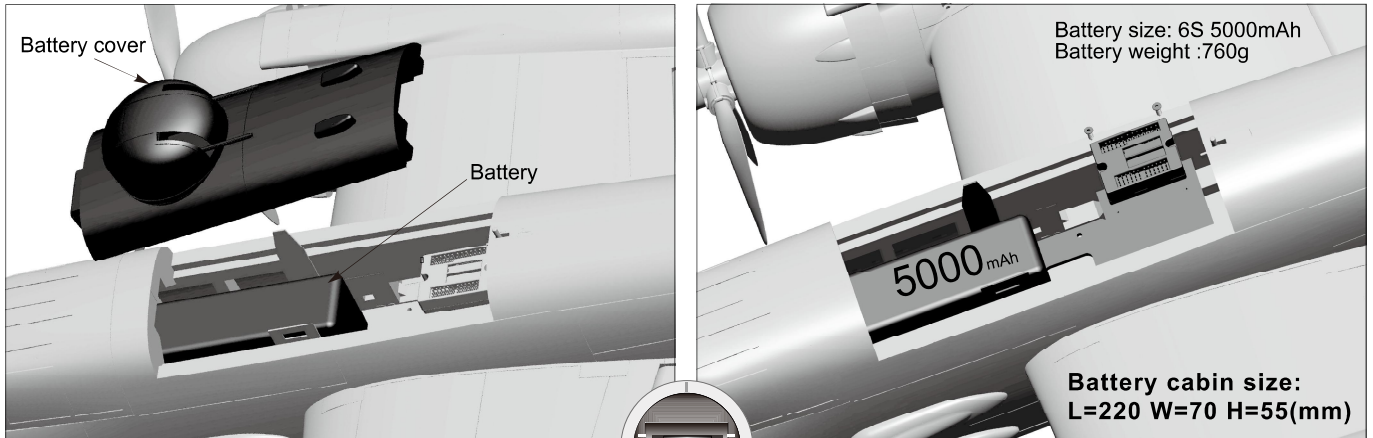

Before connecting the battery and receiver, please switch on the transmitter power and make sure the throttle stick is in the lowest position. Bind your receiver to your transmitter according to your transmitter's instruction manual.



We recommend the following LiPo battery:
6S 22.2V 5000mAh~6S 22.2V 6000mAh
Discharge rate of C ≥ 35C

Center of Gravity

Correct Center of Gravity ("CG") is critical for enabling safe aircraft stability and responsive control. Please refer to the following CG diagram to adjust your aircraft's Center of Gravity.

- Depending on the capacity and weight of your chosen flight batteries, move the battery forward or backward to adjust the Center of Gravity.
- If you cannot obtain the recommended CG by moving the battery to a suitable location, you can also install a counterweight to achieve correct CG. However, with the recommended battery size, a counterweight is not required. We recommend flying without unnecessary counterweight.

At the bottom of middle wing, close to the fuselage.
It has a CG sign.
You can according this sign to confirm the right CG.

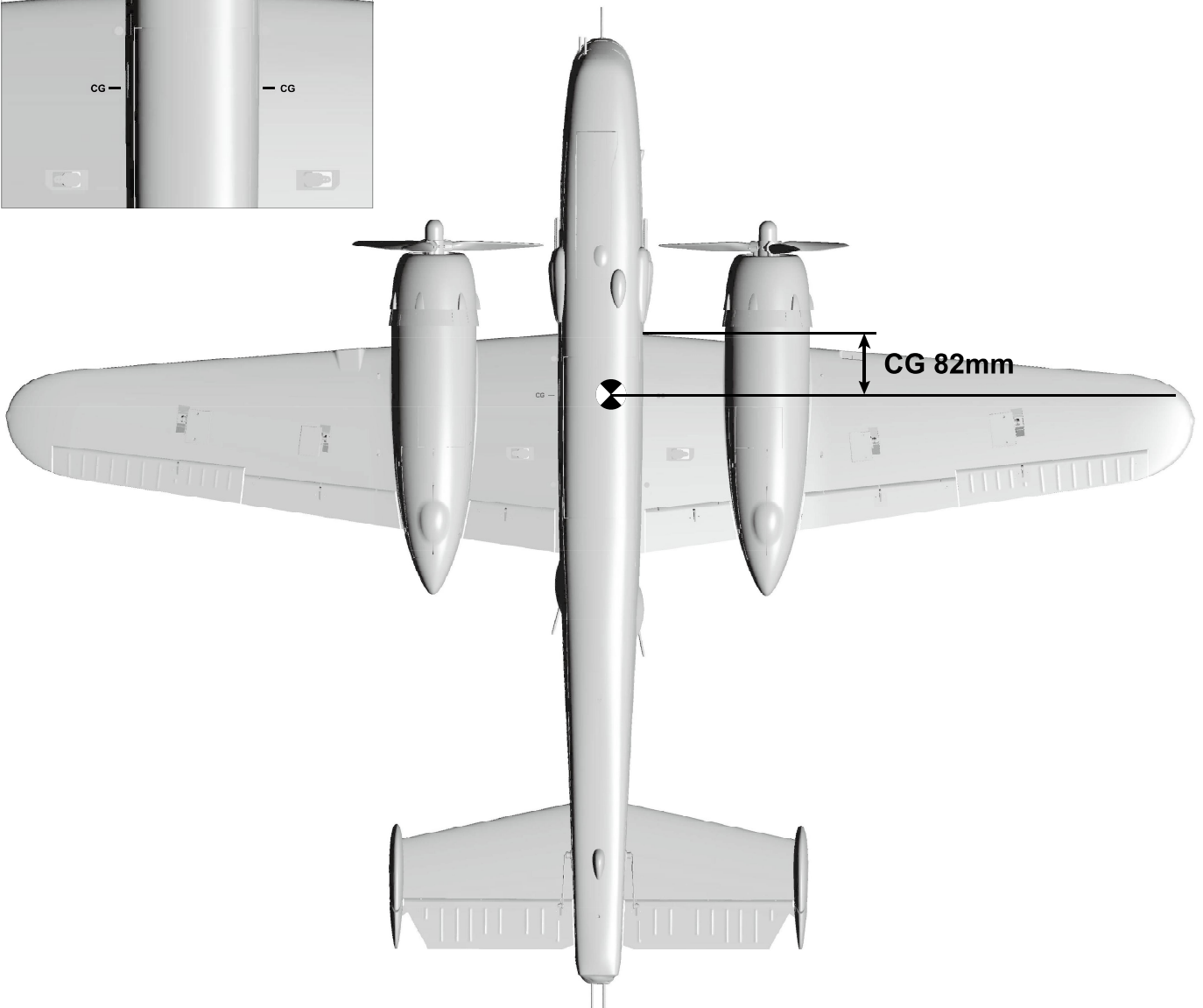

Dual Rates

According to our testing experience, use the following parameters to set Aileron/Elevator Rate. Program your preferred Exponential % in your radio transmitter. We recommend using High Rate for the first flight, and switching to Low Rate if you desire a lower sensitivity. On successive flights, adjust the Rates and Expo to suit your preference.

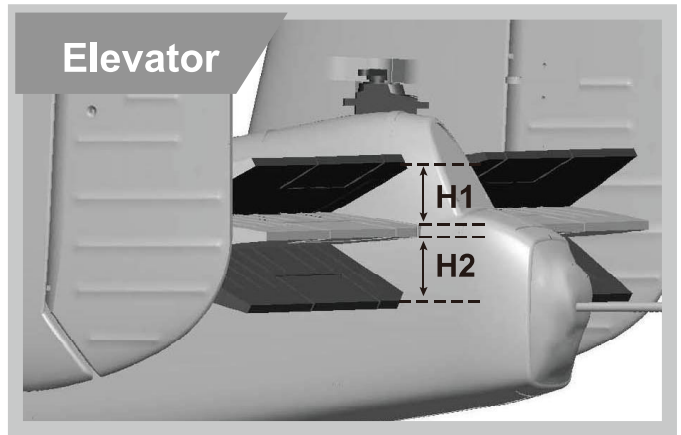
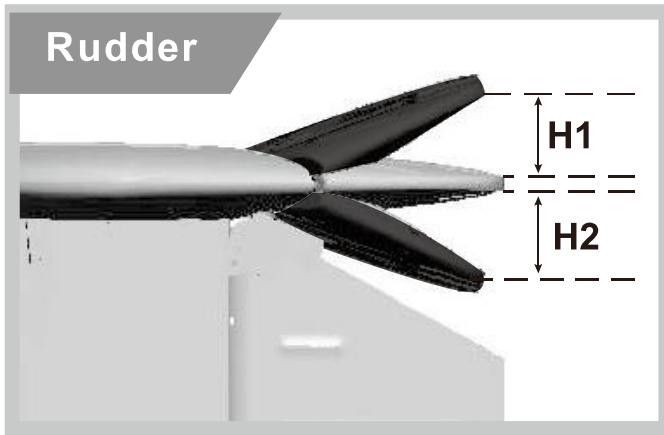
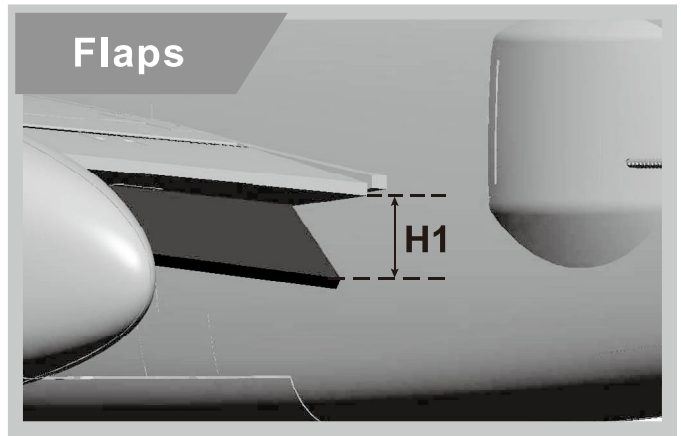
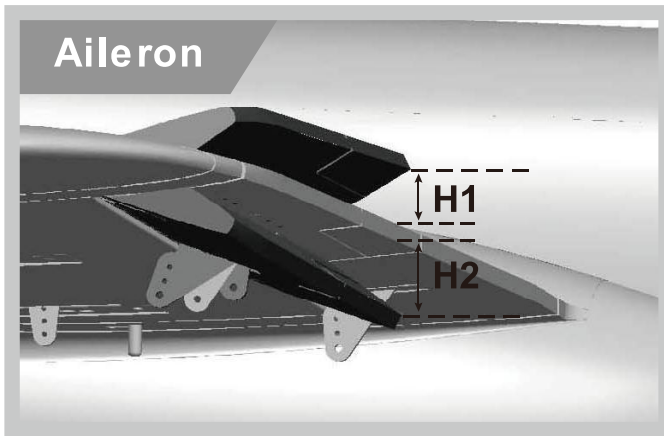

	Aileron(measured closest to the fuselage)	Elevator(measured closest to the fuselage)	Rudder(Measured from the bottom)	Flaps
Low Rate	H1/H2 22mm/ 22mm D/R Rate: 80%	H1/H2 14mm/ 14mm D/R Rate: 60%	H1/H2 18mm/ 18mm D/R Rate: 80%	H1 12mm
High Rate	H1/H2 26mm/ 26mm D/R Rate: 100%	H1/H2 18mm/ 18mm D/R Rate: 80%	H1/H2 22mm/ 22mm D/R Rate: 100%	H1 24mm

Remote Control EXP Setting Suggestion

1.Aileron EXP curve is shown as below :

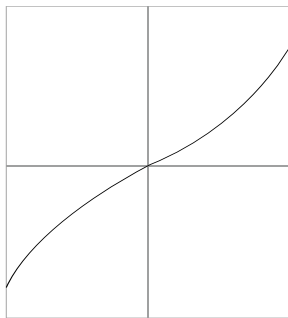

Futaba brand Remote Control : EXP A -30
EXP B -30

Spektrum brand Remote Control : EXPO 30% 30%

2.Elevator EXP curve is shown as below :

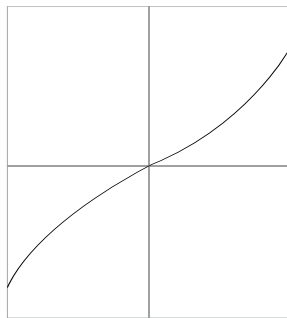

Futaba brand Remote Control : EXP A -30
EXP B -30

Spektrum brand Remote Control : EXPO 30% 30%

3.Rudder EXP curve is shown as below :

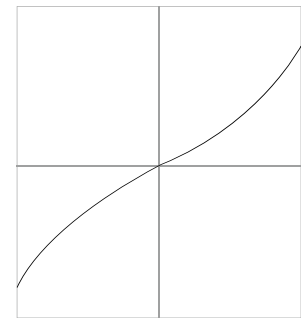

Futaba brand Remote Control : EXP A -30
EXP B -30

Spektrum brand Remote Control : EXPO 30% 30%

Flight note

1. A Flap-to-Elevator Mix is required to maintain level flight when the flaps are developed. With flaps (Low Rate), mix 1mm of Down Elevator. With flaps (High Rate), mix 3mm to Down Elevator.
2. Because it has two ESC and two motors, it is necessary to calibrate the throttle during the first flight or after replacing the remote control, in order to ensure that the pulling force of the two motors is consistent. Please refer to the electric adjustment manual for specific calibration methods.

Control Direction Test

After installed the plane, before flying, we need a fully charged battery and connect to the ESC, then use radio to test and check that every control surface work properly.

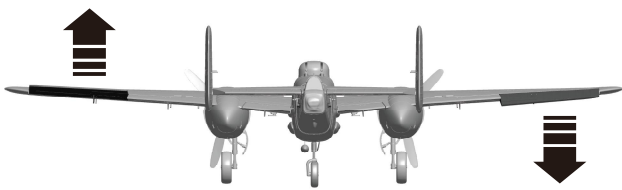
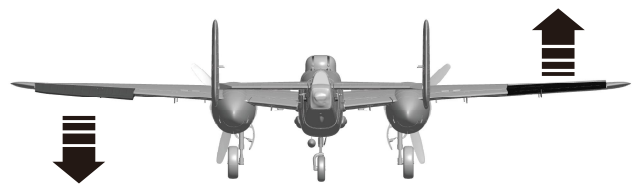
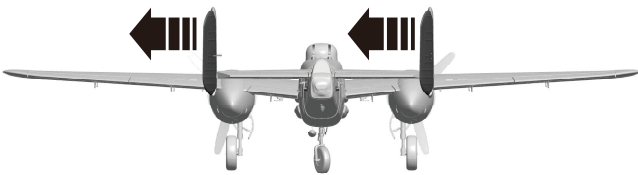
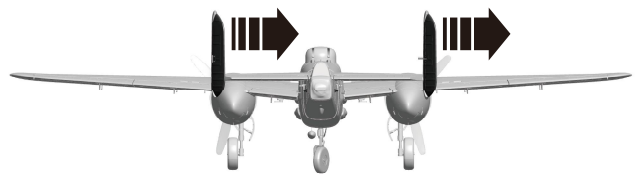
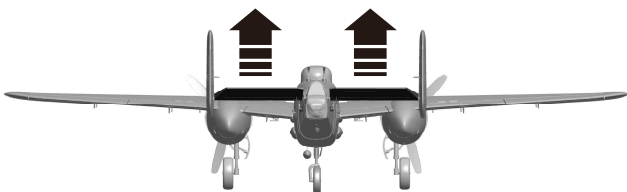
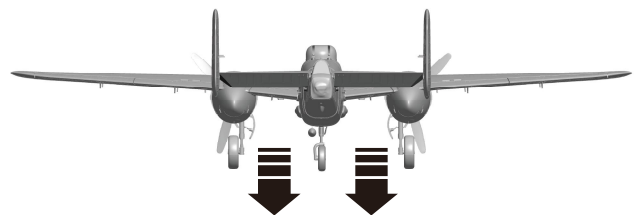
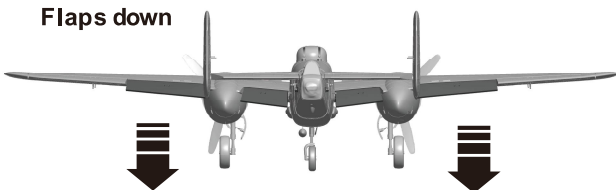
Aileron**Stick Left****Stick Right****Rudder****Stick Left****Stick Right****Elevator****Stick down****Stick up****Flaps****Flaps down**

Servo Direction

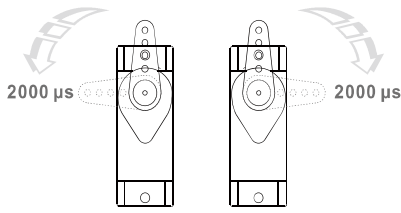

The servo positive or reverse rotation is defined as follows:
 When servo input signal change from 1000μs to 2000μs,
 The servo arm is rotated clockwise, its positive servo.
 The servo arm is rotated counterclockwise, its reverse servo.

If you need to purchase another brand's servo, please refer to the following list to choose a suitable servo.

Position	Servo regulation	No.	Pos. / Rev.	Cable length
Nose gear steering servo	9g Digital-Hybrid	1	Positive	500mm
Bombs compartment door	9g Digital-Plastic	2	Positive	300mm
Nose cabin door	9g Digital-Plastic	3	Positive	400mm
Rear cabin door(L)	9g Digital-Plastic	4	Positive	300mm
Rear cabin door(R)	9g Digital-Plastic	5	Reverse	300mm
Flap(Inside-L)	9g Digital-Hybrid	6	Reverse	100mm
Flap(Inside-R)	9g Digital-Hybrid	7	Positive	100mm
Flap(Outside-L)	9g Digital-Hybrid	8	Positive	200mm
Flap(Outside-R)	9g Digital-Hybrid	9	Positive	200mm
Aileron(L)	17g Digital-MG	10	Positive	300mm
Aileron(R)	17g Digital-MG	11	Positive	300mm
Rudder(L)	9g Digital-Hybrid	12	Positive	600mm
Rudder(R)	9g Digital-Hybrid	13	Positive	600mm
Elevator(L)	17g Digital-MG	14	Positive	300mm
Elevator(R)	17g Digital-MG	15	Reverse	300mm

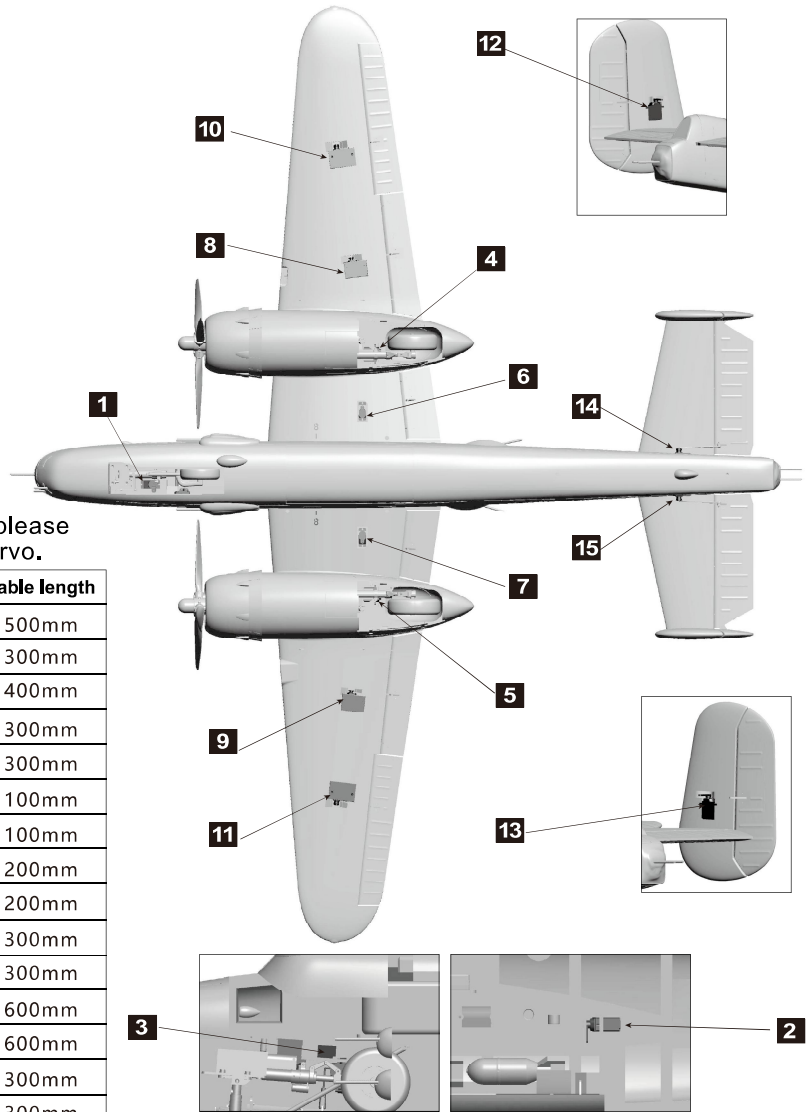

Motor Specification

#MO137485
 3748-450KV

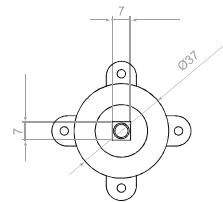
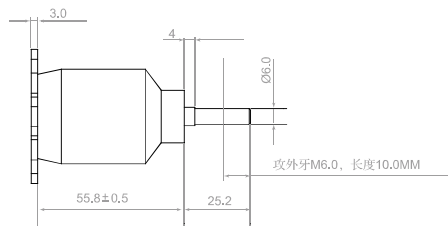
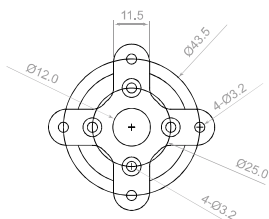

Unit: mm

Item No.	KV Value	Volute (V)	Current (A)	Pull (g)	Motor Resistance	Weight (g)	No Load Current	Propeller	ESC
MO137485	450RPM/V	22.2	33	2900	0.02Ω	205	2.3A/10V	3-Blade 12x7	≥ 50A

